

Qualitäts-Spannsätze für hohe Drehmomente.
Kurze Einbauzeit.

Typ: HT 10

Toleranzen: Welle h8, Nabe H8
Oberflächenrauigkeit: Rt max 16 µm
Rundlauffehler: 0,02 mm ÷ 0,04 mm

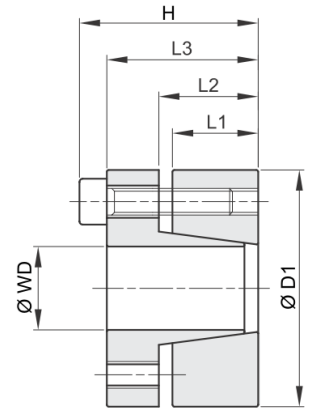

Best. Nr.	WD	D1	L1	L2	L3	H	Drehm. Mt (nM)	Axialkraft F ax. (KN)	Welle pw N/mm ²	Nabe pn N/mm ²	Anz. Schraub.	Schr. Typ
498-010-0019	19	47	17	22	28	34	273	29	262	106	5	M6x20
498-010-0020	20	47	17	22	28	34	287	29	249	106	5	M6x20
498-010-0022	22	47	17	22	28	34	316	29	227	106	5	M6x20
498-010-0024	24	50	17	22	28	34	413	34	249	120	6	M6x20
498-010-0025	25	50	17	22	28	34	431	34	239	120	6	M6x20
498-010-0028	28	55	17	22	28	34	482	34	213	109	6	M6x20
498-010-0030	30	55	17	22	28	34	517	34	199	109	6	M6x20
498-010-0032	32	60	17	22	28	34	734	46	249	133	8	M6x20
498-010-0035	35	60	17	22	28	34	803	46	227	133	8	M6x20
498-010-0038	38	65	17	22	28	34	872	46	210	122	8	M6x20
498-010-0040	40	65	17	22	28	34	918	46	199	122	8	M6x20
498-010-0042	42	75	20	25	33	41	1563	74	261	146	7	M8x25
498-010-0045	45	75	20	25	33	41	1674	74	244	146	7	M8x25
498-010-0050	50	80	20	25	33	41	1860	74	219	137	7	M8x25
498-010-0055	55	85	20	25	33	41	2340	85	228	148	8	M8x25
498-010-0060	60	90	20	25	33	41	2553	85	209	139	8	M8x25
498-010-0065	65	95	20	25	33	41	3110	96	217	149	9	M8x25
498-010-0070	70	110	24	30	40	50	4838	138	243	154	8	M10x30
498-010-0075	75	115	24	30	40	50	5184	138	226	148	8	M10x30
498-010-0080	80	120	24	30	40	50	5530	138	212	142	8	M10x30
498-010-0085	85	125	24	30	40	50	6610	156	225	153	9	M10x30
498-010-0090	90	130	24	30	40	50	6998	156	212	147	9	M10x30
498-010-0095	95	135	24	30	40	50	8208	173	223	157	10	M10x30
498-010-0100	100	145	26	32	44	56	9742	195	221	152	8	M12x35
498-010-0110	110	155	26	32	44	56	10716	195	201	143	8	M12x35
498-010-0120	120	165	26	32	44	56	13154	219	207	151	9	M12x35
498-010-0130	130	180	34	40	52	64	18996	292	195	141	12	M12x35
498-010-0140	140	190	34	40	54	68	20336	291	180	133	9	M14x40
498-010-0150	150	200	34	40	54	68	24211	323	187	140	10	M14x40
498-010-0160	160	210	34	40	54	68	28408	355	192	147	11	M14x40
498-010-0170	170	225	44	50	64	78	32929	387	153	115	12	M14x40
498-010-0180	180	235	44	50	64	78	34866	387	144	110	12	M14x40

Qualitäts-Spannsätze für hohe Drehmomente.
Kurze Einbauzeit.

Typ: HT 11

Toleranzen: Welle h8, Nabe H8
Oberflächenrauigkeit: Rt max 16 µm
Rundlauffehler: 0,02 mm ÷ 0,04 mm

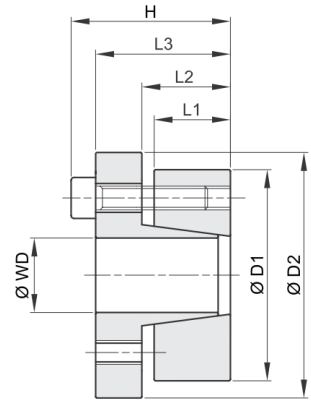

Best. Nr.	WD	D1	L1	L2	L3	H	D2	Drehm. Mt (nM)	Axialkraft F ax. (KN)	Welle pw N/mm ²	Nabe pn N/mm ²	Anz. Schr.	Schr. Typ
498-011-0019	19	47	17	22	28	34	56	243	26	234	94	5	M6x20
498-011-0020	20	47	17	22	28	34	56	256	26	222	94	5	M6x20
498-011-0022	22	47	17	22	28	34	56	282	26	202	94	5	M6x20
498-011-0024	24	50	17	22	28	34	59	368	31	222	106	6	M6x20
498-011-0025	25	50	17	22	28	34	59	383	31	213	106	6	M6x20
498-011-0028	28	55	17	22	28	34	64	429	31	190	97	6	M6x20
498-011-0030	30	55	17	22	28	34	64	460	31	177	97	6	M6x20
498-011-0032	32	60	17	22	28	34	69	655	41	222	118	8	M6x20
498-011-0035	35	60	17	22	28	34	69	716	41	203	118	8	M6x20
498-011-0038	38	65	17	22	28	34	74	778	41	187	109	8	M6x20
498-011-0040	40	65	17	22	28	34	74	819	41	178	109	8	M6x20
498-011-0042	42	75	20	25	33	41	84	1361	65	227	127	7	M8x25
498-011-0045	45	75	20	25	33	41	84	1458	65	212	127	7	M8x25
498-011-0050	50	80	20	25	33	41	84	1620	65	191	119	7	M8x25
498-011-0055	55	85	20	25	33	41	94	2037	74	199	129	8	M8x25
498-011-0060	60	90	20	25	33	41	99	2223	74	182	121	8	M8x25
498-011-0065	65	95	20	25	33	41	104	2710	83	189	126	9	M8x25
498-011-0070	70	110	24	30	40	50	119	4203	120	211	134	8	M10x30
498-011-0075	75	115	24	30	40	50	124	4754	120	197	128	8	M10x30
498-011-0080	80	120	24	30	40	50	129	4804	120	184	123	8	M10x30
498-011-0085	85	125	24	30	40	50	134	5742	135	195	133	9	M10x30
498-011-0090	90	130	24	30	40	50	139	6080	135	184	128	9	M10x30
498-011-0095	95	135	24	30	40	50	144	7131	150	194	137	10	M10x30
498-011-0100	100	145	26	32	44	56	154	8732	175	198	137	8	M12x35
498-011-0110	110	155	26	32	44	56	164	9605	175	180	128	8	M12x35
498-011-0120	120	165	26	32	44	56	174	11787	196	186	135	9	M12x35
498-011-0130	130	180	34	40	52	64	189	17024	262	175	126	12	M12x35
498-011-0140	140	190	34	40	54	68	199	18703	267	166	122	9	M14x40
498-011-0150	150	200	34	40	54	68	209	22259	297	172	129	10	M14x40
498-011-0160	160	210	34	40	54	68	219	26119	326	177	135	11	M14x40
498-011-0170	170	225	44	50	64	78	234	30276	356	140	106	12	M14x40
498-011-0180	180	235	44	50	64	78	244	32057	356	133	102	12	M14x40

Qualitäts-Spannsätze für hohe Drehmomente.
Kurze Einbaulzeit.

Typ: HT 12

Toleranzen: Welle h8, Nabe H8
Oberflächenrauigkeit: Rt max 16 µm
Rundlauffehler: 0,02 mm ÷ 0,04 mm

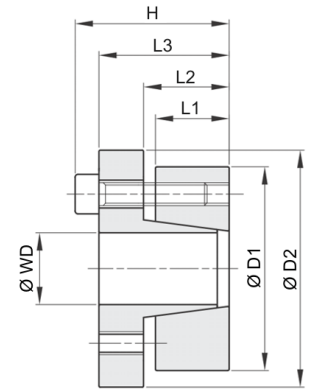

Best. Nr.	WD	D1	L1	L2	L3	H	D2	Drehm. Mt (nM)	Axialkraft F ax. (kN)	Welle pw N/mm ²	Nabe pn N/mm ²	Anz. Schr.	Schr. Typ
498-012-0114	14	55	17	22	31	39	62	234	33	415	106	4	M8x25
498-012-0116	16	55	17	22	31	39	62	268	33	363	106	4	M8x25
498-012-0118	18	55	17	22	31	39	62	333	37	357	117	4	M8x25
498-012-0119	19	55	17	22	31	39	62	352	37	338	117	4	M8x25
498-012-0120	20	55	17	22	31	39	62	370	37	321	117	4	M8x25
498-012-0122	22	55	17	22	31	39	62	407	37	292	117	4	M8x25
498-012-0124	24	55	17	22	31	39	62	445	37	268	117	4	M8x25
498-012-0125	25	55	17	22	31	39	62	463	37	257	117	4	M8x25
498-012-0128	28	55	17	22	31	39	62	519	37	229	117	4	M8x25
498-012-0130	30	55	17	22	31	39	62	556	37	214	117	4	M8x25
498-012-0224	24	65	17	22	31	39	72	556	46	335	124	5	M8x25
498-012-0225	25	65	17	22	31	39	72	579	46	321	124	5	M8x25
498-012-0228	28	65	17	22	31	39	72	649	46	287	124	5	M8x25
498-012-0230	30	65	17	22	31	39	72	695	46	268	124	5	M8x25
498-012-0232	32	65	17	22	31	39	72	741	46	251	124	5	M8x25
498-012-0235	35	65	17	22	31	39	72	811	46	230	124	5	M8x25
498-012-0238	38	65	17	22	31	39	72	880	46	211	124	5	M8x25
498-012-0240	40	65	17	22	31	39	72	927	46	201	124	5	M8x25
498-012-0330	30	80	20	25	33	41	87	972	65	318	119	7	M8x25
498-012-0332	32	80	20	25	33	41	87	1037	65	299	119	7	M8x25
498-012-0335	35	80	20	25	33	41	87	1134	65	273	119	7	M8x25
498-012-0338	38	80	20	25	33	41	87	1231	65	251	119	7	M8x25
498-012-0340	40	80	20	25	33	41	87	1296	65	239	119	7	M8x25
498-012-0342	42	80	20	25	33	41	87	1361	65	227	119	7	M8x25
498-012-0345	45	80	20	25	33	41	87	1458	65	212	119	7	M8x25
498-012-0348	48	80	20	25	33	41	87	1555	65	199	119	7	M8x25
498-012-0350	50	80	20	25	33	41	87	1620	65	191	119	7	M8x25

Qualitäts-Spannsätze für hohe Drehmomente.
Kurze Einbauzeit. Radialer Versatz ist gering. Flächen-
pressung enthalten.

Typ: HT 13

Toleranzen: Welle h8, Nabe H8
Oberflächenrauigkeit: Rt max 16 µm
Rundlauffehler: 0,02 mm ÷ 0,04 mm

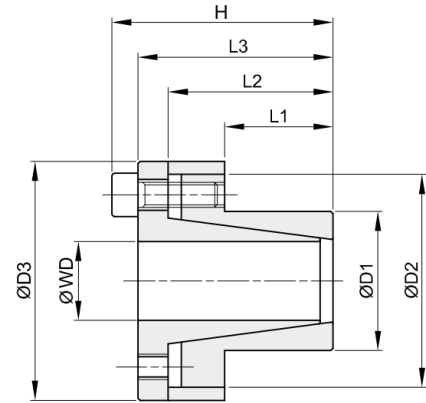

Best. Nr.	WD	D1	L1	L2	L3	H	D2	D3	Drehm. Mt (nM) ²	Axialkraft F ax. (kN) ²	Welle pw N/mm ²	Nabe pn N/mm ²	Anz. Schr.	Schr. Typ
498-013-0008	8	15	12	21	24	28	28	32	39	10	299	159	4	M4x10
498-013-0009	9	16	14	23	27	31	28	32	44	10	227	128	4	M4x12
498-013-0010	10	16	14	23	27	31	28	32	49	10	205	128	4	M4x12
498-013-0011	11	18	14	23	27	31	30	34	53	10	186	114	4	M4x12
498-013-0012	12	18	14	23	27	31	30	34	58	10	171	114	4	M4x12
498-013-0014	14	23	14	23	27	31	35	39	68	10	146	89	4	M4x12
498-013-0015	15	24	16	29	36	42	40	45	120	16	196	123	4	M6x18
498-013-0016	16	24	16	29	36	42	40	45	128	16	184	123	4	M6x18
498-013-0018	18	26	18	31	38	44	42	47	191	21	194	134	4	M6x18
498-013-0019	19	27	18	31	38	44	43	48	202	21	183	129	4	M6x18
498-013-0020	20	28	18	31	38	44	44	49	213	21	174	124	4	M6x18
498-013-0022	22	32	25	38	45	51	48	54	234	21	114	78	4	M6x18
498-013-0024	24	34	25	38	45	51	50	56	255	21	105	74	4	M6x18
498-013-0025	25	34	25	38	45	51	50	56	266	21	100	74	4	M6x18
498-013-0028	28	39	25	38	45	51	55	61	373	27	112	81	5	M6x18
498-013-0030	30	41	25	38	45	51	57	63	480	32	126	92	6	M6x18
498-013-0032	32	43	30	43	50	56	59	65	511	32	98	73	6	M6x18
498-013-0035	35	47	30	43	50	56	63	69	747	43	120	89	8	M6x18
498-013-0038	38	50	30	43	50	56	66	72	811	43	110	84	8	M6x18
498-013-0040	40	53	32	45	52	58	69	75	959	48	110	83	9	M6x18
498-013-0042	42	55	32	45	52	58	71	77	1007	48	105	80	9	M6x18
498-013-0045	45	59	40	56	64	72	79	85	1781	79	130	99	8	M8x22
498-013-0048	48	62	40	56	64	72	82	88	1900	79	122	94	8	M8x22
498-013-0050	50	65	50	66	74	82	85	92	2473	99	117	90	10	M8x22
498-013-0055	55	71	50	66	74	82	91	98	2721	99	106	82	10	M8x22
498-013-0060	60	77	50	66	74	82	97	104	2968	99	97	76	10	M8x22
498-013-0065	65	84	50	66	74	82	104	111	3215	99	90	69	10	M8x22
498-013-0070	70	90	60	80	91	101	115	122	4430	127	89	69	8	M10x25
498-013-0075	75	95	60	80	91	101	119	126	5338	142	93	74	9	M10x25
498-013-0080	80	100	65	85	96	106	124	131	7595	190	108	86	12	M10x25
498-013-0085	85	106	65	85	96	106	130	137	8069	190	101	81	12	M10x25
498-013-0090	90	112	65	85	96	106	136	143	9968	222	112	90	14	M10x25

Qualitäts-Spannsätze für hohe Drehmomente.
Kurze Einbauzeit. Radialer Versatz ist gering. Flächen-
pressung enthalten.

Typ: HT 13

Toleranzen: Welle h8, Nabe H8
Oberflächenrauigkeit: Rt max 16 µm
Rundlauffehler: 0,02 mm ÷ 0,04 mm

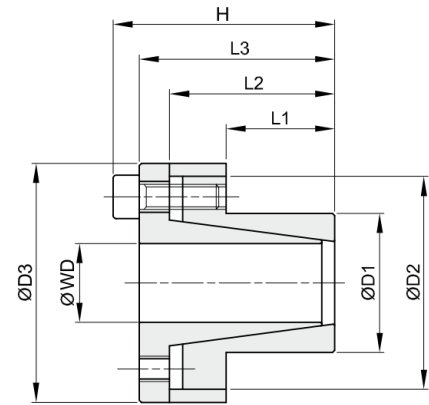

Best. Nr.	WD	D1	L1	L2	L3	H	D2	D3	Drehm. Mt (nM) ²	Axialkraft F ax. (kN) ²	Welle pw N/mm ²	Nabe pn N/mm ²	Anz. Schr.	Schr. Typ
498-013-0095	95	120	65	85	96	106	144	153	10522	222	106	84	14	M10x25
498-013-0100	100	125	65	89	102	114	153	162	13651	273	124	99	12	M12x30
498-013-0110	110	140	70	94	107	119	168	177	15016	273	105	82	12	M12x30
498-013-0120	120	155	90	114	127	139	185	195	21844	364	99	77	16	M12x30
498-013-0130	130	165	90	114	127	139	195	205	23664	364	92	72	16	M12x30
498-013-0140	140	175	90	114	127	139	205	215	25485	364	85	68	16	M12x30
498-013-0150	150	185	90	114	127	139	215	225	27305	364	80	64	16	M12x30

Qualitäts-Spannsätze für hohe Drehmomente.
Kurze Einbauzeit.

Typ: HT 14

Toleranzen: Welle h8, Nabe H8
Oberflächenrauigkeit: Rt max 16 µm
Rundlauffehler: 0,02 mm ÷ 0,04 mm

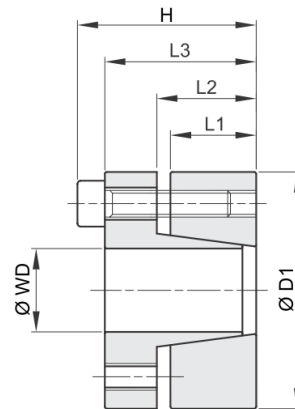

Best. Nr.	WD	D1	L1	L2	L3	H	Drehm. Mt (nM)	Axialkraft F ax. (KN)	Welle pw N/mm ²	Nabe pn N/mm ²	Anz. Schr.	Schr. Typ
498-014-0019	19	47	26	31	39	45	307	32	193	78	4	M6x25
498-014-0020	20	47	26	31	39	45	323	32	183	78	4	M6x25
498-014-0022	22	47	26	31	39	45	355	32	166	78	4	M6x25
498-014-0024	24	50	26	31	39	45	582	48	229	110	6	M6x25
498-014-0025	25	50	26	31	39	45	606	48	220	110	6	M6x25
498-014-0028	28	55	26	31	39	45	679	48	196	100	6	M6x25
498-014-0030	30	55	26	31	39	45	727	48	183	100	6	M6x25
498-014-0032	32	60	26	31	39	45	1033	65	229	122	8	M6x25
498-014-0035	35	60	26	31	39	45	1130	65	209	122	8	M6x25
498-014-0038	38	65	26	31	39	45	1227	65	193	113	8	M6x25
498-014-0040	40	65	26	31	39	45	1292	65	183	113	8	M6x25
498-014-0042	42	75	30	36	47	55	1835	87	204	115	6	M8x30
498-014-0045	45	75	30	36	47	55	1966	87	191	115	6	M8x30
498-014-0048	48	80	30	36	47	55	2097	87	179	107	6	M8x30
498-014-0050	50	80	30	36	47	55	2184	87	172	107	6	M8x30
498-014-0055	55	85	30	36	47	55	3202	116	208	135	8	M8x30
498-014-0060	60	90	30	36	47	55	3493	116	191	127	8	M8x30
498-014-0065	65	95	30	36	47	55	3784	116	176	120	8	M8x30
498-014-0070	70	110	40	46	57	67	6607	189	199	127	8	M10x35
498-014-0075	75	115	40	46	62	72	7079	189	186	121	8	M10x35
498-014-0080	80	120	40	46	62	72	7551	189	174	116	8	M10x35
498-014-0085	85	125	40	46	62	72	10029	236	205	139	10	M10x35
498-014-0090	90	130	40	46	62	72	10619	236	193	134	10	M10x35
498-014-0095	95	135	40	46	62	72	11209	236	183	129	10	M10x35
498-014-0100	100	145	46	52	77	89	13738	275	176	121	8	M12x45
498-014-0110	110	155	46	52	77	89	15111	275	160	114	8	M12x45
498-014-0120	120	165	46	52	77	89	20606	343	183	133	10	M12x45
498-014-0130	130	180	46	52	77	89	26788	412	203	147	12	M12x45
498-014-0140	140	190	51	59	84	98	26142	373	154	114	8	M14x45
498-014-0150	150	200	51	59	84	98	35016	467	180	135	10	M14x45
498-014-0160	160	210	51	59	84	98	37351	467	169	129	10	M14x45
498-014-0170	170	225	51	59	84	98	47617	560	191	144	12	M14x45
498-014-0180	180	235	51	59	84	98	50418	560	180	138	12	M14x45

Qualitäts-Spannsätze für hohe Drehmomente.
Kurze Einbauzeit

Typ: HT 15

Toleranzen: Welle h8, Nabe H8
Oberflächenrauigkeit: Rt max 16 µm
Rundlauffehler: 0,02 mm ÷ 0,04 mm

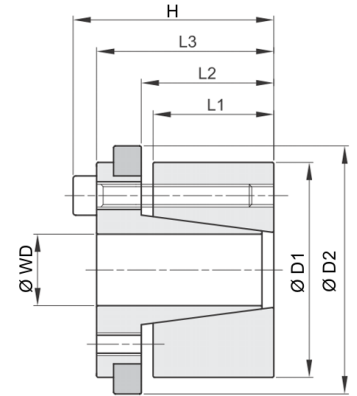

Best. Nr.	WD	D1	L1	L2	L3	H	D2	Drehm. Mt (nM)	Axialkraft F ax. (KN)	Welle pw N/mm ²	Nabe pn N/mm ²	Anz. Schr.	Schr. Typ
498-015-0019	19	47	26	31	39	45	53	202	21	127	51	4	M6x20
498-015-0020	20	47	26	31	39	45	53	213	21	121	51	4	M6x20
498-015-0022	22	47	26	31	39	45	53	234	21	110	51	4	M6x20
498-015-0024	24	50	26	31	39	45	56	384	32	151	73	6	M6x20
498-015-0025	25	50	26	31	39	45	56	400	32	145	73	6	M6x20
498-015-0028	28	55	26	31	39	45	61	448	32	129	66	6	M6x20
498-015-0030	30	55	26	31	39	45	61	480	32	121	66	6	M6x20
498-015-0032	32	60	26	31	39	45	66	683	43	151	81	8	M6x20
498-015-0035	35	60	26	31	39	45	66	747	43	138	81	8	M6x20
498-015-0038	38	65	26	31	39	45	71	811	43	127	74	8	M6x20
498-015-0040	40	65	26	31	39	45	71	853	43	121	74	8	M6x20
498-015-0042	42	75	30	36	47	55	81	1216	58	135	76	6	M8x30
498-015-0045	45	75	30	36	47	55	81	1302	58	126	76	6	M8x30
498-015-0048	48	80	30	36	47	55	86	1389	58	119	71	6	M8x30
498-015-0050	50	80	30	36	47	55	86	1447	58	114	71	6	M8x30
498-015-0055	55	85	30	36	47	55	91	2124	77	138	89	8	M8x30
498-015-0060	60	90	30	36	47	55	96	2317	77	127	84	8	M8x30
498-015-0065	65	95	30	36	47	55	101	2510	77	117	80	8	M8x30
498-015-0070	70	110	40	46	57	67	116	4381	125	132	84	8	M10x35
498-015-0075	75	115	40	46	62	72	121	4694	125	123	80	8	M10x35
498-015-0080	80	120	40	46	62	72	126	5007	125	115	77	8	M10x35
498-015-0085	85	125	40	46	62	72	131	6651	156	136	92	10	M10x35
498-015-0090	90	130	40	46	62	72	136	7042	156	128	89	10	M10x35
498-015-0095	95	135	40	46	62	72	141	7433	156	121	85	10	M10x35
498-015-0100	100	145	46	52	77	89	151	9104	182	117	81	8	M12x45
498-015-0110	110	155	46	52	77	89	161	10015	182	106	75	8	M12x45
498-015-0120	120	165	46	52	77	89	171	13653	228	122	88	10	M12x45
498-015-0130	130	180	46	52	77	89	186	17747	273	135	97	12	M12x45
498-015-0140	140	190	51	59	84	98	196	17328	248	102	75	8	M14x45
498-015-0150	150	200	51	59	84	98	206	23207	309	119	89	10	M14x45
498-015-0160	160	210	51	59	84	98	216	24754	309	112	85	10	M14x45
498-015-0170	170	225	51	59	84	98	231	31561	371	126	95	12	M14x45
498-015-0180	180	235	51	59	84	98	241	33417	371	119	91	12	M14x45

Qualitäts-Spannsätze für sehr hohe Drehmomente.

Typ: HT 16

Toleranzen: Welle h8, Nabe H8
 Oberflächenrauigkeit: Rt max 16 µm
 Rundlauffehler: 0,02 mm ÷ 0,04 mm

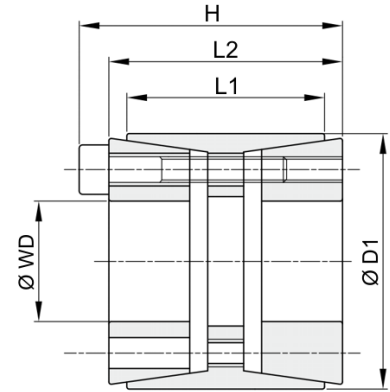

Bestellnummer	WD	D1	L1	L2	H	Dr. Mt (nM)	Ax-Kr. F ax. KN	W. pw N/mm2	Nabe pn N/mm2	Anz. Schr.	Schr. Typ
498-016-0025	25	55	32	40	46	799	64	314	107	6	M6x35
498-016-0028	28	55	32	40	46	895	64	281	107	6	M6x35
498-016-0030	30	55	32	40	46	959	64	262	107	6	M6x35
498-016-0035	35	60	44	54	60	1306	75	185	83	7	M6x45
498-016-0038	38	75	44	54	62	2567	135	308	121	7	M8x50
498-016-0040	40	75	44	54	62	2702	135	293	121	7	M8x50
498-016-0042	42	75	44	54	62	2837	135	279	121	7	M8x50
498-016-0045	45	75	44	54	62	3040	135	260	121	7	M8x50
498-016-0048	48	80	56	64	62	3707	154	216	102	8	M8x55
498-016-0050	50	80	56	64	72	3861	154	207	102	8	M8x55
498-016-0055	55	85	56	64	72	4779	174	212	108	9	M8x55
498-016-0060	60	90	56	64	72	5793	193	216	113	10	M8x55
498-016-0065	65	95	56	64	72	6276	193	199	107	10	M8x55
498-016-0070	70	110	70	78	88	10951	313	235	120	10	M10x60
498-016-0075	75	115	70	78	88	11733	313	220	115	10	M10x60
498-016-0080	80	120	70	78	88	13768	344	227	121	11	M10x60
498-016-0085	85	125	70	78	88	15959	376	233	127	12	M10x60
498-016-0090	90	130	70	78	88	16898	376	220	122	12	M10x60
498-016-0095	95	135	70	78	88	17837	376	208	117	12	M10x60
498-016-0100	100	145	90	100	112	25029	501	211	113	11	M12x80
498-016-0110	110	155	90	100	112	30039	546	209	115	12	M12x80
498-016-0120	120	165	90	100	112	38226	637	224	127	14	M12x80
498-016-0130	130	180	104	116	130	48270	743	201	117	12	M14x90
498-016-0140	140	190	104	116	130	60654	866	217	129	14	M14x90
498-016-0150	150	200	104	116	130	69628	928	217	132	15	M14x90
498-016-0160	160	210	104	116	130	79220	990	217	134	15	M14x90
498-016-0170	170	225	134	148	164	100851	1186	206	116	14	M16x110
498-016-0180	180	235	134	148	164	114414	1271	208	119	15	M16x110
498-016-0190	190	250	134	148	164	128814	1356	210	119	16	M16x110
498-016-0200	200	260	134	148	164	135594	1356	200	115	16	M16x110
498-016-0220	220	285	134	148	164	167805	1356	204	118	18	M16x110
498-016-0240	240	305	134	148	164	218000		184	119	20	M16x110
498-016-0260	260	325	134	148	164	250000		178	117	21	M16x110
498-016-0280	280	355	165	177	197	360000		185	117	18	M20x130
498-016-0300	300	375	165	177	197	428000		192	123	20	M20x130

Qualitäts-Spannsätze für hohe Drehmomente.
Kurze Einbauzeit.

Typ: HT 17

Toleranzen: Welle h11, Nabe H11
Oberflächenrauigkeit: Rt max 16 µm

Für gute Rundlaufgenauigkeit Welle und Nabe exakt ausrichten.

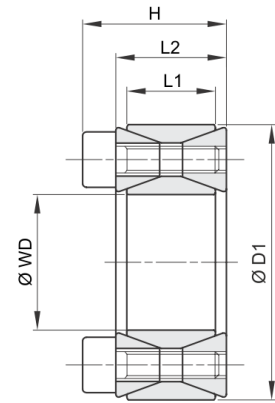

Best. Nr.	WD	D1	L1	L2	H	Drehm. Mt (nM)	Axialkraft F ax. (KN)	Welle pw N/mm ²	Nabe pn N/mm ²	Anz. Schr.	Schr. Typ
498-017-0019	19	47	17	20	26	298	31	286	116	8	M6x18
498-017-0020	20	47	17	20	26	313	31	272	116	8	M6x18
498-017-0022	22	47	17	20	26	345	31	247	116	8	M6x18
498-017-0024	24	50	17	20	26	424	35	255	123	9	M6x18
498-017-0025	25	50	17	20	26	441	35	245	123	9	M6x18
498-017-0028	28	55	17	20	26	549	39	243	124	10	M6x18
498-017-0030	30	55	17	20	26	588	39	227	124	10	M6x18
498-017-0032	32	60	17	20	26	752	47	255	136	12	M6x18
498-017-0035	35	60	17	20	26	822	47	233	136	12	M6x18
498-017-0038	38	65	17	20	26	1042	55	250	146	14	M6x18
498-017-0040	40	65	17	20	26	1097	55	238	146	14	M6x18
498-017-0042	42	75	20	24	32	1740	83	291	163	12	M8x22
498-017-0045	45	75	20	24	32	1864	83	271	163	12	M8x22
498-017-0048	48	80	20	24	32	1988	83	254	153	12	M8x22
498-017-0050	50	80	20	24	32	2071	83	244	153	12	M8x22
498-017-0055	55	85	20	24	32	2658	97	259	168	14	M8x22
498-017-0060	60	90	20	24	32	2900	97	238	158	14	M8x22
498-017-0065	65	95	20	24	32	3587	110	250	171	16	M8x22
498-017-0070	70	110	24	28	38	5345	153	268	171	14	M10x25
498-017-0075	75	115	24	28	38	5727	153	250	163	14	M10x25
498-017-0080	80	120	24	28	38	6108	153	235	156	14	M10x25
498-017-0085	85	125	24	28	38	7417	175	252	172	16	M10x25
498-017-0090	90	130	24	28	38	7854	175	238	165	16	M10x25
498-017-0095	95	135	24	28	38	9326	196	254	179	18	M10x25
498-017-0100	100	145	26	33	45	11362	227	258	178	14	M12x30
498-017-0110	110	155	26	33	45	12498	227	234	166	14	M12x30
498-017-0120	120	165	26	33	45	15578	260	245	178	16	M12x30
498-017-0130	130	180	34	38	50	21095	325	217	156	20	M12x35
498-017-0140	140	190	34	38	50	24993	357	221	163	22	M12x35
498-017-0150	150	200	34	38	50	29217	390	225	169	24	M12x35
498-017-0160	160	210	34	38	50	33756	422	229	174	26	M12x35
498-017-0170	170	225	38	44	58	39483	465	212	160	22	M14x40

Qualitäts-Spannsätze für hohe Drehmomente.
Kurze Einbauzeit.

Typ: HT 17

Toleranzen: Welle h11, Nabe H11
Oberflächenrauigkeit: Rt max 16 µm

Für gute Rundlaufgenauigkeit Welle und Nabe exakt ausrichten.

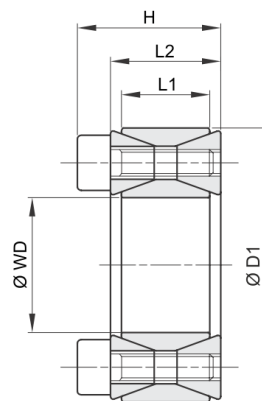

Best. Nr.	WD	D1	L1	L2	H	Drehm. Mt (nM)	Axialkraft F ax. (KN)	Welle pw N/mm ²	Nabe pn N/mm ²	Anz. Schr.	Schr. Typ
498-017-0180	180	235	38	44	58	45606	507	218	167	24	M14x40
498-017-0190	190	250	46	52	66	56163	591	199	152	28	M14x45
498-017-0200	200	260	46	52	66	63342	633	203	156	30	M14x45
498-017-0220	220	285	50	56	72	81960	745	200	154	26	M16x50
498-017-0240	240	305	50	56	72	103162	860	211	166	30	M16x50
498-017-0260	260	325	50	56	72	126669	974	221	177	34	M16x50
498-017-0280	280	355	60	66	84	157339	1124	197	156	32	M18x60
498-017-0300	300	375	60	66	84	189653	1264	207	166	36	M18x60
498-017-0320	320	405	72	78	98	264108	1651	211	167	36	M20x70

Qualitäts-Spannsätze für hohe Drehmomente.
Kurze Einbauzeit.

Typ: HT 18

Toleranzen: Welle h8, Nabe H8
Oberflächenrauigkeit: Rt max 16 µm
Rundlauffehler: 0,02 mm ÷ 0,04 mm

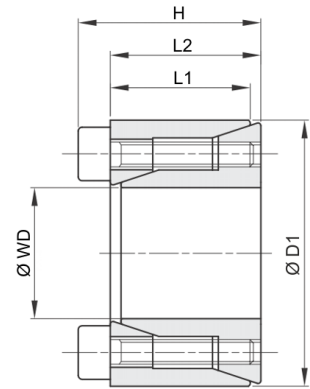

Bestellnummer	WD	D1	L1	L2	H	Dr. Mt (nM)	Ax-Kr. F ax. KN	W. pw N/mm2	Nabe pn N/mm2	Anz. Schr.	Schr. Typ
498-018-0005	5	16	10,5	11	13,5	6	2,0	150	55	3	M2,5x10
498-018-0006	6	16	10,5	11	13,5	6	2,0	150	55	3	M2,5x10
498-018-0007	6,35	16	10,5	11	13,5	6	2,0	140	55	3	M2,5x10
498-018-0008	8	18	10,5	11	13,5	10	2,5	110	50	3	M2,5x10
498-018-0009	9	20	12,5	13	15,5	15	3,0	120	55	4	M2,5x10
498-018-0010	10	20	12,5	13	15,5	19	3,8	124	62	4	M2,5x10
498-018-0011	11	22	12,5	13	15,5	21	3,8	113	56	4	M2,5x12
498-018-0012	12	22	12,5	13	15,5	23	3,8	104	56	4	M2,5x12
498-018-0014	14	26	16,5	17	20	39	5,5	106	57	4	M3x16
498-018-0015	15	28	16,5	17	20	42	5,5	99	53	4	M3x16
498-018-0016	16	32	16,5	17	21	77	9,6	161	81	4	M4x16
498-018-0017	17	35	20,5	21	25	82	9,6	119	58	4	M4x20
498-018-0018	18	35	20,5	21	25	87	9,6	113	58	4	M4x20
498-018-0019	19	35	20,5	21	25	91	9,6	107	58	4	M4x20
498-018-0020	20	38	20,5	21	26	157	15,7	166	87	4	M5x20
498-018-0022	22	40	20,5	21	26	173	15,7	151	83	4	M5x20
498-018-0024	24	47	25	26	32	268	22,3	171	87	4	M6x24
498-018-0025	25	47	25	26	32	279	22,3	164	87	4	M6x24
498-018-0028	28	50	25	26	32	468	33,5	220	123	6	M6x24
498-018-0030	30	55	25	26	32	502	33,5	206	112	6	M6x24
498-018-0032	32	55	25	26	32	535	33,5	193	112	6	M6x24
498-018-0035	35	60	30	31	37	781	44,6	188	110	8	M6x28
498-018-0038	38	65	30	31	37	848	44,6	173	101	8	M6x28
498-018-0040	40	65	30	31	37	892	44,6	164	101	8	M6x28
498-018-0042	42	75	35	36	44	1272	60,6	177	99	6	M8x34
498-018-0045	45	75	35	36	44	1363	60,6	165	99	6	M8x34
498-018-0048	48	80	35	36	44	1938	80,8	207	124	8	M8x34
498-018-0050	50	80	35	36	44	2019	80,8	198	124	8	M8x34

